

RF-RS-T Battery Powered Temperature Sensors



Features:

- Up to 5 years battery life
- Encrypted data transmission
- Configurable parameters

Benefits:

- Self-healing tree topology
- Lower installation costs
- Easy to install and commission

Technical Overview

These battery powered sensors are used in conjunction with the Sontay RF-RX20 or RF-RX40 receiver units, and RF-RR series of 24V powered routers.

Data is transmitted back to the receiver at configurable time intervals, or on a configurable change in measured value. Each sensor retains these configurations even if the battery becomes discharged or requires replacement.

Sensors automatically find the best path back to the receiver, which may be directly to the receiver or via other 'parent' routers.

Tel: +44 (0)1732 861200. - **E-mail:** sales@sontay.com. - **Web:** www.sontay.com.

© 2012 Sontay Limited. All rights reserved

Specification:

Part Codes:

Common specification:

Radio Output:	
Frequency	2.4GHz
16 channels, automatically selected	
Direct-sequence spread spectrum	
Compliance	IEEE 802.15.4-2006
Data Encryption	AES 128
Power Output	0dBm
Temperature accuracy	±0.3°C
Operating:	
Temperature	-10 to +50°C
RH	0 to 90%, non-condensing
Country of origin	UK

Plant Housing:

Material	ABS (flame retardant type VO)
Dimensions	75 x 70 x 50mm
Battery (non-rechargeable):	
Type	3.6V 2/3 Li-SOCl ₂
Life	>3 years (dependent on conf.)
Protection:	
Snap-shut lid	IP54
	IP65 (see page 4 note 8)
Probe material	PTFE (332) Stainless steel (others)
Probe dimensions:	
(322 & 341)	150mm x 6mm dia.
(331)	10mm dia.
(332)	40 x 16mm dia. cable 2 meters
(555)	30 x 6mm dia. cable 2-5 meters

Aerial Characteristics:

Gain	2.0dBi
VSWR	<2:1

Space Housing:

Material	ABS (flame retardant)
Dimensions	85 x 85 x 23mm
Battery (non-rechargeable):	
Type	3.6V AA Li-SOCl ₂ ,
Life	>3 years (dependent on conf.)
Protection	IP30
Aerial Characteristics:	
Gain	1.2dBi
VSWR	1.5:1



The products referred to in this data sheet meet the requirements of EU Directive 2004/108/E

RF-RS-T-911

Space temperature sensor

Options (for -911 only)

-MS	Momentary switch
-SP	Set-point adjust

RF-RS-T-322

Duct temperature sensor

RF-RS-T-342

Immersion temperature sensor

RF-RS-T-352

Clamp-on temperature sensor

RF-RS-T-331

Outside air temperature sensor

RF-RS-T-332

Outside air temperature with radiation shield sensor

RF-RS-T-555-2

Flying lead temperature sensor, 2m cable

RF-RS-T-555-5

Flying lead temperature sensor, 5m cable

How It Works:

Data is transmitted back to the receiver at configurable time intervals, or on a configurable change in measured value. Each sensor retains these configurations if the battery becomes discharged or requires replacement.

The sensors, routers and receiver automatically select which of the 16 transmission channels available gives the best radio network performance, taking into account both signal strength and interference levels from adjacent channels and equipment (such as Wi-Fi etc.) The sensors automatically find the best path back to the receiver, which may be directly to the receiver or via "parent" routers.

Aerial Orientation (plant sensor types);

For best results ensure that the main body of the aerial is vertical.

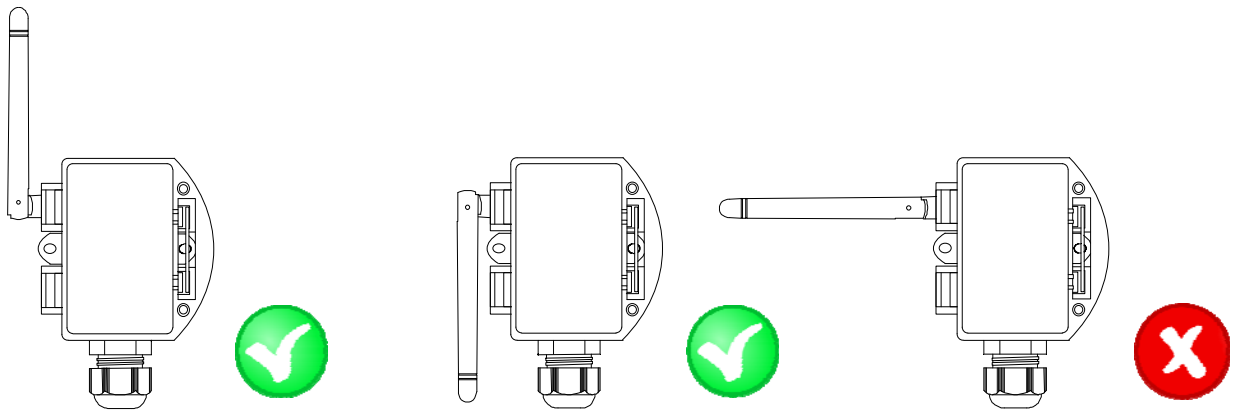

Installation:

Plant Sensor types:

1. Remove all packaging from the sensor.
2. Note the MAC address printed on the affixed label and note where this MAC address is installed.
3. Mount the sensor in the required position (this will have been determined by the site survey tool, (see the quick start guide and manual).
4. See page 4 for individual installation depending on sensor type.
5. Release the snap-fit lid by gently squeezing the locking tab and install the Li-SOCl₂ battery, observing the correct polarity.
6. Snap shut the lid after the connections have been made if IP65 protection is required, secure the lid with two screws provided.
7. Ensure, at a minimum, that all routers and the receiver on the radio network are powered on, and allow about 5 minutes for the network to auto-commission before attempting to read values or make configuration changes.

Tel: +44 (0)1732 861200. - E-mail: sales@sontay.com. - Web: www.sontay.com.

© 2012 Sontay Limited. All rights reserved

Installation (continued):

Duct

- Select a location in the duct where the sensor probe will give a representative sample of the prevailing air condition.
- Drill a 7mm diameter hole in the duct, then use the housing as a template mark the hole centres or use the dimensions below), drill and fix the housing to the duct with the screws supplied.

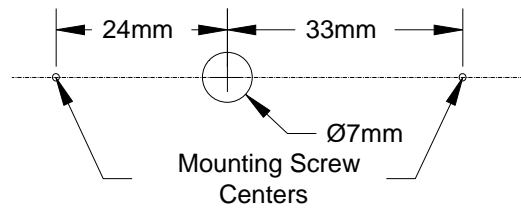

Immersion

- Select a location in the system where the liquid is to be measured, install pocket as per datasheet TT-PO.
- Insert the probe into the pocket and secure with the grub screw provided within the pocket.
- The immersion sensor must be used with a pocket, it is not designed for direct mounting.

Clamp-on

- Select a location in the system where the liquid temperature is to be measured, where the brass lug will make good contact with the surface of the pipe.
- Secure the brass lug to the surface to the pipe using the clip provided. Wrap the clip around the pipe and place the lug under the strap and tighten the clip. It is good practice to ensure that good contact is made between the lug and the pipe, and apply insulation over the pipe and lug.

Outside air

- Select a suitable location preferably on a north facing wall, ensuring that the sensor is away from direct sunlight and any heat sources.

Outside air with radiation shield

- Select a suitable location, the sensor has a radiation shield that helps minimize error gains from direct sunlight.

Space Sensor Types:

1. Remove all packaging from the sensor.
2. Note the MAC address printed on the affixed label and note where this MAC address is installed.
3. Mount the sensor in the required position (this will have been determined by the site survey tool, (see the quick start guide and manual).
4. Using the base as a template mark the hole centres and fix to the wall with suitable screws. Alternatively the base plate can be mounted on to a conduit box or a standard recessed back box.
5. Install the Li-SOCl₂ battery, observing the correct polarity. To power on the unit, fit J400.

Tel: +44 (0)1732 861200. - E-mail: sales@sontay.com. - Web: www.sontay.com.

© 2012 Sontay Limited. All rights reserved

Installation (continued):

Space Sensor Types:

6. Replace the housing to the base plate.
7. Re-fit the tamperproof screw through the lug at the bottom of the base plate.
8. Ensure, at a minimum, that all routers and the receiver on the radio network are powered on, and allow about 5 minutes for the network to auto-commission before attempting to read values or make configuration changes.

Battery Fitting & Replacement:

The current battery level of a sensor can be monitored using the CMS software connected to the receiver. When a battery is first installed, or when it is replaced, observe the correct polarity. **Fitting the battery incorrectly may result in permanent damage to the sensor.** Remove the power jumper prior to removing a battery. After fitting a battery, replace the power jumper while pressing the reset button. This resets the hours run counter for the battery.

NB Lithium-Thionyl Chloride batteries are **not rechargeable**, and should be stored in a clean, cool (not exceeding +30°C), dry and ventilated area.

Disposal of Batteries - Warning! Fire, Explosion and Burn Hazard.

Do not recharge, short-circuit, crush, disassemble heat above 100°C (212°F), incinerate, or expose the battery contents to water. Do not solder directly to the cell.

All batteries must be disposed of in accordance with EC Directive 2006/66/EC, amended by EU Directive 2008/12/EC.

Whilst every effort has been made to ensure the accuracy of this specification, Sontay cannot accept responsibility for damage, injury, loss or expense from errors or omissions. In the interest of technical improvement, this specification may be altered without notice.

Tel: +44 (0)1732 861200. - **E-mail:** sales@sontay.com. - **Web:** www.sontay.com.

© 2012 Sontay Limited. All rights reserved